

WINDSHIELDS AND WINDOWS - DESCRIPTION AND OPERATION

1. General

A. This section covers windshields and windows used on various Model 208 airplanes. For an illustration of window locations, refer to Figure 1.

B. If it is necessary to inspect the windshield, refer to Windshields and Windows - Inspection/Check.

2. Description

A. Flight compartment windows consist of left and right windshields, right forward crew door window and left forward crew door window including a hinged vent window.

(1) Flight compartment windshields are comprised of two-piece, 0.312 inch thick, green-tinted acrylic.

B. Cabin windows are made of 0.187 inch thick, green-tinted acrylic. Locations and numbers vary with different Model 208 configurations.

(1) On the Model 208 only, windows in the cabin consist of four observation windows on the right side of the airplane and three observation windows on the left side of the airplane.

(2) On the Model 208B Passenger only, windows in the cabin consist of six observation windows on the right side and five observation windows on the left side.

(3) The airplane door windows in the cabin section consist of one window in the right-hand upper passenger door and two windows in the left-hand upper cargo door.

Figure 1 : Sheet 1 : Window Locations

A22204

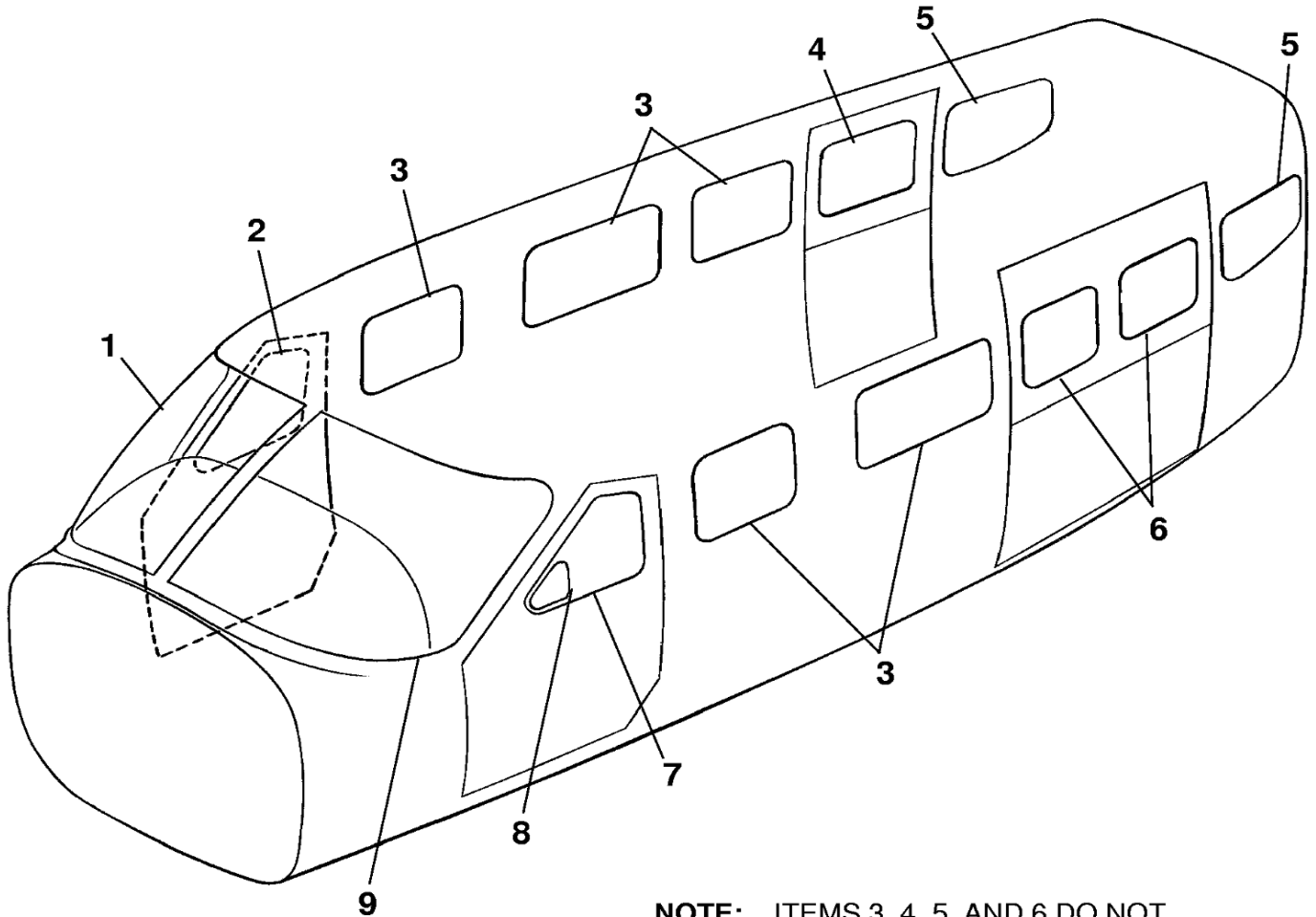

NOTE: ITEMS 3, 4, 5, AND 6 DO NOT APPLY TO MODEL 208B.

1. RIGHT WINDSHIELD
2. RIGHT FORWARD CREW DOOR WINDOW
3. CENTER CABIN WINDOWS
4. PASSENGER DOOR WINDOW
5. AFT CABIN WINDOWS
6. CARGO DOOR WINDOW
7. LEFT FORWARD CREW DOOR WINDOW
8. VENT WINDOW
9. LEFT WINDSHIELD

MODEL 208 ONLY

26112004

Figure 1 : Sheet 2 : Window Locations

A22205

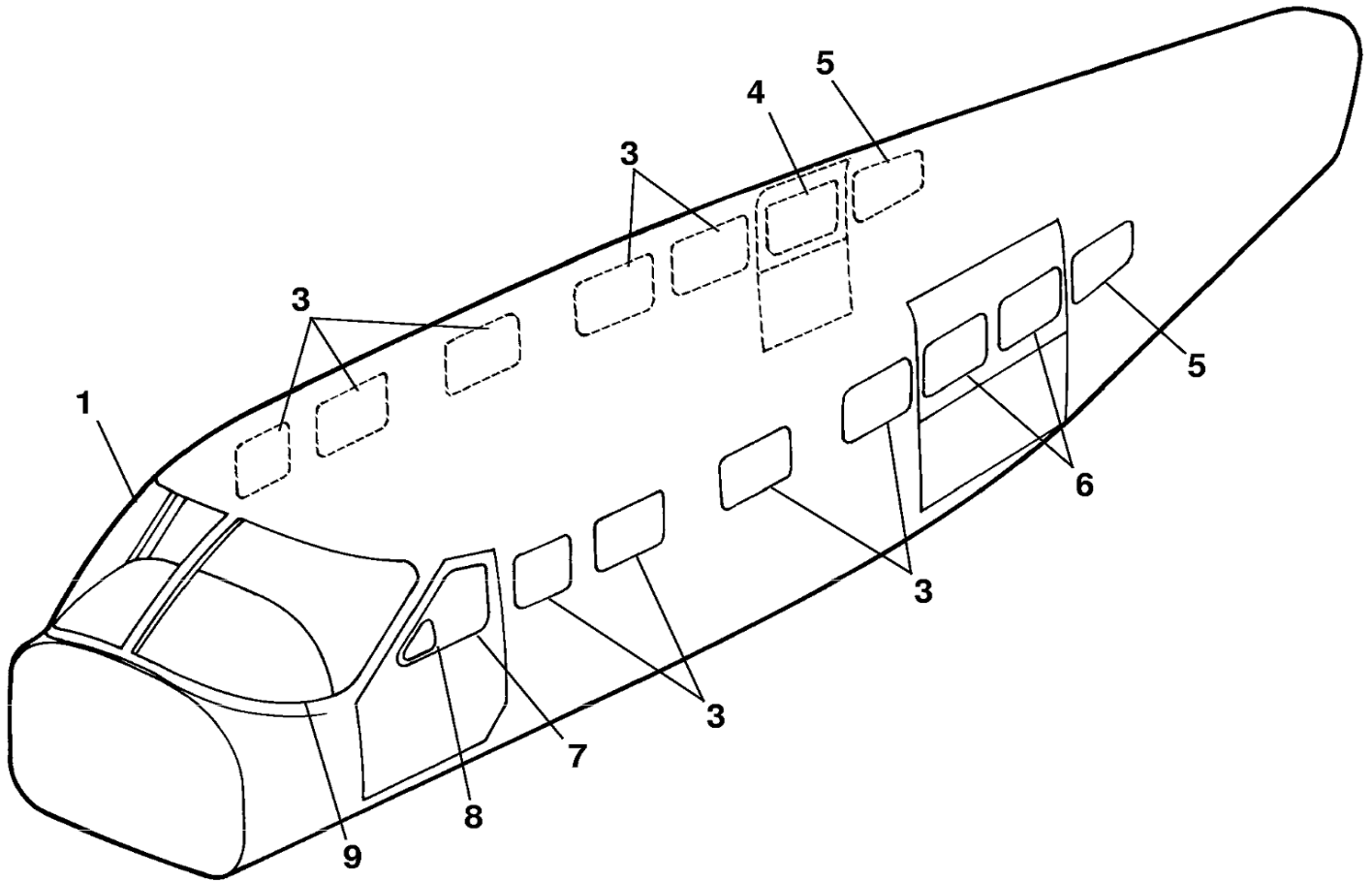

1. RIGHT WINDSHIELD
3. CENTER CABIN WINDOWS
4. PASSENGER DOOR WINDOW
5. AFT CABIN WINDOWS
6. CARGO DOOR WINDOW
7. LEFT FORWARD CREW DOOR WINDOW
8. VENT WINDOW
9. LEFT WINDSHIELD

MODEL 208B PASSENGER ONLY

26112006